



«TiSO-PRODUCTION» Company

**SERVO-OPERATED  
ROTOR TURNSTILE  
T3.POC.XC**



**OPERATION MANUAL  
AUIA.123.1 OM**

## CONTENTS

	Page
INTRODUCTION.....	3
1 DESCRIPTION AND OPERATION.....	5
1.1 General Information and Designation.....	5
1.2 Specifications.....	6
1.3 Configuration and Completeness of Delivery.....	6
1.4 Design and Operation.....	7
1.5 Instrumentation, tools and accessories.....	8
1.6 Marking.....	8
1.7 Packing.....	9
1.8 Description and operation of controller as component of the turnstile.....	9
2 INTENDED USE.....	16
2.1 Operating limitations.....	16
2.2 Layout and installation.....	17
2.3 Preparation for use.....	17
2.4 Contingency actions.....	19
3 MAINTENANCE.....	19
3.1 General instructions.....	19
3.2 Safety measures.....	19
3.3 Maintenance procedure.....	19
4 ROUTINE MAINTENANCE.....	20
4.1 General instructions.....	20
4.2 Fault Directory.....	20
4.3 Post repair checkout.....	20
5 TRANSPORTATION AND STORAGE .....	20
6 UTILIZATION.....	21
7 MANUFACTURER’S WARRANTY AND CONDITIONS OF INTERMEDIATE MAINTENANCE.....	21
Appendix A Design, overall and installation dimensions of the rotor turnstile T3.POC.XC .....	22
Appendix B Control panel and connection diagram.....	23
Appendix C Wiring diagram of the turnstile T3.POC.XC .....	25

## INTRODUCTION

This Operation Manual (hereinafter referred to as the OM), combined with certificate, covers the servo-operated rotor waist-high turnstile (hereinafter referred to as the turnstile). The Operation Manual contains information about design, specifications, installation, proper operation and maintenance of the turnstile.

This Operation Manual is prepared in compliance with the specification requirements TU U 31.6-32421280-004:2010.

The turnstile should be serviced only by the qualified staff having the relevant class of permit to work with electrical facilities with voltage up to 1000V, who carefully studied this Operation Manual, obtained safety instructions and trained for operation and maintenance of the turnstile.

Reliability and durability of the turnstile operation is provided with observation of modes and conditions of transportation, storage, installation and operation. So, fulfillment of all requirements specified in this document is mandatory.

In view of regularly performed works on improvement of the product, its design can be modified without degradation of parameters and quality of the product.

Depending on the purpose and design features of the turnstile, the following pattern of product reference designation is accepted:

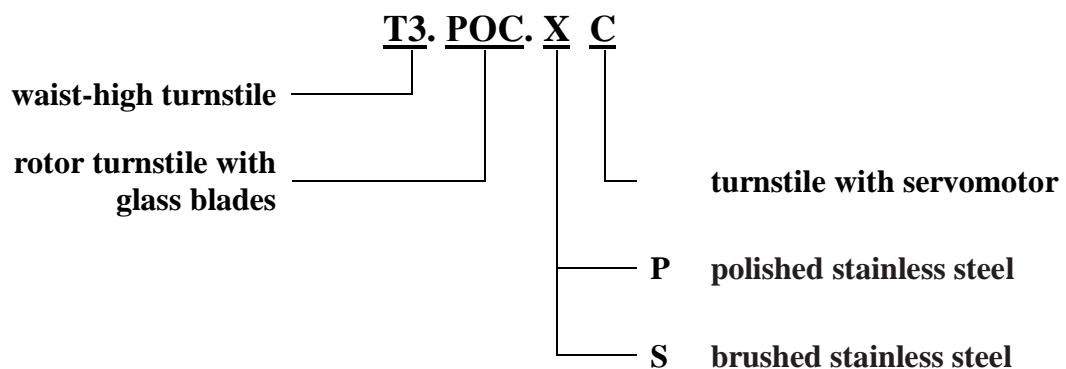

Example of reference designation of the servo-operated rotor turnstile with glass blades and brushed stainless steel housing when the turnstile

T3.POC.SC TU U 31.6-32421280-004:2010 is ordered.

## **WARNINGS TO THE CUSTOMER ON SAFE OPERATION OF THE TURNSTILE**

These warnings are designed for ensuring of safety during operation of the turnstile to prevent violation of safety characteristics by improper installation or operation. These warnings are aimed at drawing attention of the customer to safety problems.

### **GENERAL WARNINGS**

Safety measures and requirements specified in this in this OM must be observed:

the turnstile must be connected to ground loop prior to operation;

- the turnstile should be connected to AC network with parameters specified in the paragraph 1.2 «Specifications»;
- inspection, adjustment and repair should be performed only after the turnstile is deenergized.

After purchasing of the turnstile it should be unpacked and its integrity should be checked. In case of doubt in integrity of the turnstile it should not be used and the customer should refer to the supplier or to the manufacturer.

Packing accessories (wooden pallet, nails, clips, polyethylene bags, cardboard etc.) as potential sources of hazard must be removed to unacceptable place prior to proper use of the turnstile.

As electric shock protection device the turnstile is related to 01 protection class according to the GOST (State Standard) 12.2.007.0-75 and is not intended for operation in explosive and fire-hazardous areas by the «Rules for design of electrical installations».

Using of the turnstile for unintended purpose, improper installation, nonobservance of conditions of transportation, storage, installation and operation specified by this OM, may result in damage to people, animals or property for which the manufacturer is not responsible.

# 1 DESCRIPTION AND OPERATION

## 1.1 General Information and Designation

1.1.1 Name of product: Rotor waist-high turnstile

Climatic version: NF4

1.1.2 The turnstile is designed for pedestrian movement control during tight access control at access points of industrial enterprises, banks, stadiums, administrative facilities etc. under actuation of control signals (from magnetic card readers, keypad etc.) of access control system or manually (from manual control panel).

Traffic flow capacity of the turnstile without personal identification is at least 20 persons per minute.

1.1.3 Dimensions and weight of the turnstile correspond to the values specified in the Table 1.

Table 1

Designation of modification	Dimensions, mm			Max. weight, kg
	H	L	W	
T3.POC.PC	1000	1450	1350	70
T3.POC.SC				

1.1.4 The parameters defining operation conditions according to GOST 15150-69 and GOST 12997-84 are specified in the Table 2.

Table 2

Operation conditions	For climatic version	Parameter value
Ambient temperature	NF4	+1°C to + 40°C
Relative humidity		80 % at + 20 °C
Ambient temperature allowable pressure		84 to 106,7 kPa
Transportation temperature range		- 40°C to + 50 °C
Storage temperature range		+ 5°C to + 40°C
Group of mechanical application		L3
Altitude above sea level		up to 2000 m
Environment		Explosion-proof, does not contain current-conducting dust, aggressive gases and vapours in concentration destroying isolation and metals, disturbing normal operation of the equipment installed in turnstiles
Installation site		In enclosed spaces in the absence of direct impact of precipitations and solar radiation
Running position		Vertical, deviation from vertical position no more than 1° to any side is acceptable

1.1.5 Reliability indices:

- mean time to repair (without delivery time of spare parts, tools and accessories) – at most 6 hours;
- mean time to failure – at least 1 500 000 accesses;
- mean service life between overhauls – at least 10 years.

## 1.2 Specifications

Principal parameters of the turnstile are specified in the Table 3.

Table 3

Parameter description	Unit measure	Parameter value
Traffic flow capacity in free access mode is at least	man/min.	60
Traffic flow capacity in single access mode is at least	man/min.	20
Max. passageway width	mm	580
Supply voltage:		
– AC power supply (primary)	V Hz	100÷240 ~ 50/60
– DC power supply (secondary)	B	12
Max. power consumption	V·A	75
Index of protection according to GOST 14254-96	–	IP41

### 1.3 Configuration and Completeness of Delivery

#### 1.3.1 Turnstile design

1.3.1.1 Design of the rotor turnstile includes the following principal devices and components:

- housing;
- side enclosure;
- central enclosure.

The turnstile housing consists of:

- cup;
- clip with plates;
- disk;
- three glass blades;
- sheeting;
- drive;
- control box.

The turnstile includes control panel.

Design, overall and installation dimensions of the turnstile are shown in the Appendix A.

1.3.1.2 The turnstile modifications are manufactured from the following materials:

- polished stainless steel (reference designation T3.POC.PC);
- brushed stainless steel (reference designation T3.POC.SC).

The turnstile's basic modification is with brushed stainless steel housing (reference designation T3.POC.SC).

#### 1.3.2 Completeness of Delivery

For convenience of delivery the turnstile is supplied by the following components:

- 1) assembled turnstile;
- 2) side enclosure;
- 3) central enclosure.

The turnstile is delivered by one package.

Completeness of delivery is specified in the Table 4.

Table 4

Product description	Product designation/parameters	Quantity, piece	Notes
Rotor turnstile	T3.POC._____	1 kit	–
<u>Components</u>			
Servomotor turnstile	AUIA.123.00.00.00.00.1	1	–
Side enclosure	AUIA.121.02.00.00.00	1	–
Central enclosure	AUIA.121.03.00.00.00	1	–
<u>Additional equipment</u>			

Control panel	AUIA.114.02.00.00	1	–
Mounting kit	Redibolt 92F112A4-0 (12×140 M10)	4	–
	Redibolt 92F110A2-0 (10×120 M8)	12	–
Reader rack*:		2	Modification of rack is defined by the order
– with LED display panel**	AUIA.121.04.00.00.00.01(-06)		
– without LED display panel	AUIA.121.04.00.00.00		
Certificate	AUIA.123.1 PS	1	–
Packing	–	1	–
* Optional ** LED display operation on the reader racks AUIA.121.04.00.00.00-01(-06) is described further in the text with the mark <sup>1</sup>			

## 1.4 Design and operation

### 1.4.1 Turnstile design

1.4.1.1 The turnstile housing consists of cup 2 with fixed base plate (see the Figure 1). Three glass blades, fixed by clip with plates 7, are mounted on top of cup. The blades 1 are radially located at the angle of 120°. Bottom surface of the turnstile housing is sheeting 3 consisting of two detachable parts.

Control box 4 and drive are located at the bottom of housing. After each turnstile access the blades are automatically brought to initial position by means of servomotor.

1.4.1.2 Control box 4 is a metal case inserted into cup. Power supply unit and card, on which controllers with electronic components and connectors for external connections are placed, are fixed inside control box case.

Control box is designed for the turnstile energizing and latching control.

1.4.1.3 Enclosures and turnstile are installed in such a way that passageway between enclosures will be locked by turnstile blade.

1.4.1.4 Control panel is made as small desktop device in plastic case designed for setting and indication of operating modes when the turnstile is operated manually. Control panel and its connection diagram are shown in the Appendix B.

### 1.4.2 Principle of operation

1.4.2.1 The turnstile's operating modes:

- 1) single access in the direction «A» or «B»;
- 2) locking;
- 3) free access in the direction «A» or «B».

Switching of the turnstile operating modes as well as setting of access modes are performed either by control panel or as part of automated access control system (ACS) (by means of cards, badges etc.).

1.4.2.2 In the initial state, when the turnstile is energized, blades are locked from rotation by drive.

1.4.2.3 After coming of access permission command in the direction «A» or «B» to controller the green arrow is lit in the appropriate direction<sup>1</sup> and blades are unlocked. After blade is gently pushed in the direction of access servomotor is actuated and rotates blades in the appropriate direction.

After the turnstile access blades keep on rotating smoothly forward (turn additionally) gradually slowing down and when 120° turning angle is reached the blades are locked by electromagnetic brake of operating mechanism.

More detailed description of the turnstile operating modes is given in the paragraph 1.8 «Description and operation of controller as component of the turnstile».

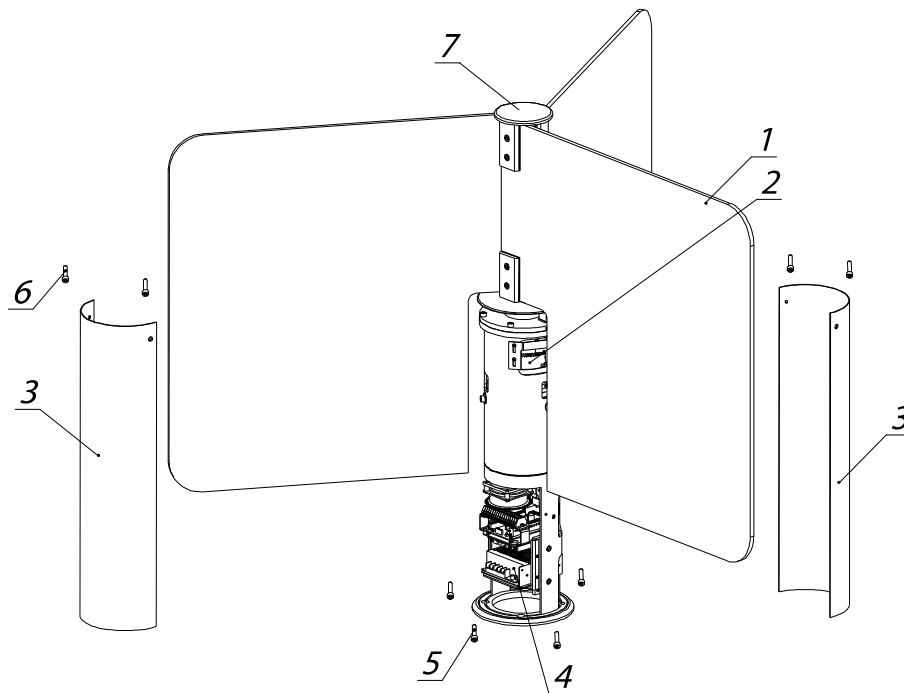

- |                     |                      |
|---------------------|----------------------|
| 1 – glass blades;   | 5 – Redibolt;        |
| 2 – cup with drive; | 6 – screws M4x10;    |
| 3 – sheeting;       | 7 – clip with plates |
| 4 – control box;    |                      |

Figure 1 – Design of the rotor turnstile T3.POC.XC

1.4.2.4 12V DC power voltage is provided by power supply unit.

1.4.2.5 The turnstile's wiring diagram is shown in the Appendix C.

### 1.5 Instrumentation, tools and accessories

Dedicated tools are required for installation of the turnstile (multi-purpose measurement instrumentation and installation tools are enough).

### 1.6 Marking

1.6.1 Marking of turnstiles to be delivered within Ukraine is in Ukrainian language and for export delivery in English.

Each turnstile is marked as follows:

- name of manufacturer and trade mark;
- each turnstile is equipped with identification plate containing the following data;
- reference designation of turnstile modification;
- index of protection;
- serial number;
- value of voltage, type of current, frequency and current consumption;
- weight, kg;
- marks of conformity to  $\text{GOST}$ ,  $\text{CE}$ ;



- date of manufacture;
- inscription «MADE IN UKRAINE».

Marking plate is located inside the turnstile housing.

1.6.2 Marking of transportation packing contains as follows:

1) Information inscriptions:

- turnstile reference designation;
- dimensions of cargo package in centimeters;
- gross weight in kg;
- net weight in kg;
- volume of package in cubic meters;

2) Handling marks:

- «Fragile. Handle with Care»;
- «Keep dry»;
- «Centre of gravity»;
- «Top».

1.6.3 Shipping documentation is packed with bag from polyethylene film. Marking is applied on insert from cardboard or paper.

## 1.7 Packing

1.7.1 The turnstile is delivered ready-to-install.

Types of packing:

- consumer packaging (corrugated cardboard case);
- transportation packaging (cases from wood-fiber board or crates).

The turnstile is fixed from displacement in the middle of transportation package with blocking lumbers. Cushion pads are placed between the turnstile and lumbers.

1.7.2 Shipping documentation sealed in a bag from polyethylene film is enclosed to the turnstile packing.

## 1.8 DESCRIPTION AND OPERATION OF CONTROLLER AS COMPONENT OF THE TURNSTILE

### 1.8.1 Motor controller PCB.201.01.00.00

The motor controller PCB.201.01.00.00 is designed to control the motorized turnstile's motor.

1.8.1.1 The controller is assembled on the (85x70)mm card, on which electronic components and connectors for external connections are mounted.

13 LED s are mounted on controller card. Their purpose is as follows:

- 8 LEDs indicate condition of inputs «IN1» ÷ «IN8».
- «POWER» LED indicates availability of supply voltage 5V.
- 4 LEDs indicate condition of outputs for connection of motor.

24 terminals are mounted on the card: 2 of them are designed for external connections, the rest are designed for connection to turnstile units or are standby.

Appearance of the controller is shown in the Figure 2.

#### 1.8.1.2 Specifications

Specifications of the controller are shown in the Table 5.

Table 5

Parameter description	Parameter value
Number of inputs	8
Number of outputs	8
Type of input	logical
Type of output GRN1, RED1, GRN2, RED2	open collector
Logical «1» voltage	(3,7÷5)V

Logical «0» voltage	(0÷1,7)V
Peak voltage applied to inputs «IN1»÷«IN8», maximum	15V
Peak voltage switched by outputs «GRN1», «RED1», «GRN2», «RED2»	30V
Peak current switched by outputs «GRN1», «RED1», «GRN2», «RED2»	2A
Peak voltage switched by outputs «-MG1», «-MG2»	50V
Peak current switched by outputs «-MG1», «-MG2»	5A
Peak voltage switched by outputs «MOT1», «MOT2»	27V
Peak current switched by outputs «MOT1», «MOT2»	≤ 4A
Controller supply voltage	(10÷27)V
Consumption current when outputs «MOT1» and «MOT2» are OFF	≤0,15 A
Climatic modification and placement category of according to the GOST 15150-69	NF4

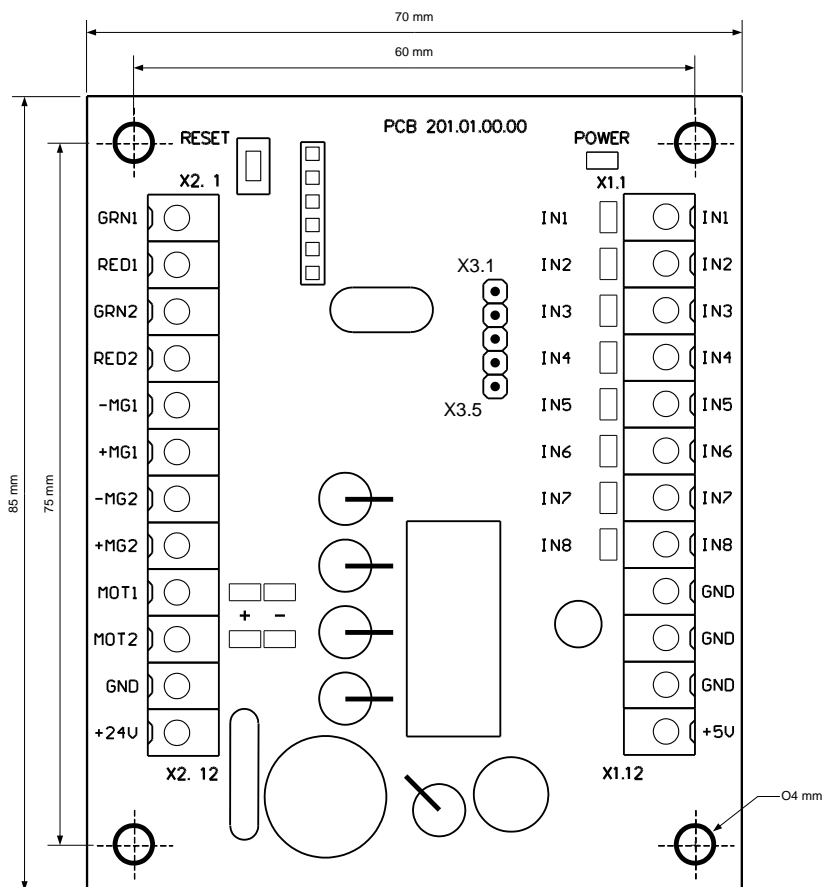

Figure 2 – Appearance of the controller PCB.201.01.00.00

### 1.8.1.3 Description of operation

1.8.1.3.1 The controller operates according to the program fed into the memory of microprocessor. The turnstile mechanism is controlled depending on commands coming from the controller PCB.112.21.20.00, present position of rotor, rotor rotation speed and motor current.

Purpose of controller's contacts is shown in the Table 6.

Table 6

Connector/ contact No	Designation	Direction	Description	Signal parameters and description
X1/1	IN1	ENTRY	Not applicable	1) logical «0» – (0÷1,7)V; 2) logical «1» – (3,7÷5)V; 3) active level of signal –
X1/2	IN2	ENTRY	Not applicable	
X1/3	IN3	ENTRY	Not applicable	
X1/4	IN4	ENTRY	Not applicable	

X1/5	IN5	ENTRY	To be connected to rotor position sensor and motor speed sensor	logical «0»; 4) voltage on open input $\leq 5V$
X1/6	IN6	ENTRY		
X1/7	IN7	ENTRY		
X1/8	IN8	ENTRY		
X1/9	GND		«-» of power supply (common wire)	
X1/10	GND			
X1/11	GND			
X1/12	+5 V	EXIT	Not applicable	
X2/1	GRN1	EXIT	Not applicable	
X2/2	RED1	EXIT	Not applicable	
X2/3	GRN2	EXIT	Not applicable	
X2/4	RED2	EXIT	Not applicable	
X2/5	-MG1	EXIT	Not applicable	1) type of output – open collector; 2) peak voltage on privacy key – 50V; 3) peak current of public key – 5A
X2/6	+MG1	EXIT	Not applicable	
X2/7	-MG2	EXIT	Connection of electromagnetic brake winding	1) type of output – open collector; 2) peak voltage on privacy key – 50V; 3) peak current of public key – 5A
X2/8	+MG2	EXIT	Connection of electromagnetic brake winding (cathode of protective diode)	
X2/9	MOT1	EXIT	Connection of motor	1) voltage (10÷27)V; 2) current $\leq 4A$
X2/10	MOT2	EXIT		
X2/11	GND		«-» of power supply (common wire)	
X2/12	+24V	ENTRY	«+» of power supply (controller energizing)	1) voltage (10÷27)V; 2) current $\leq 4A$

### 1.8.2 Turnstile controller PCB.112.21.20.00

The controller PCB.112.21.20.00 determines behavior of the whole turnstile.

1.8.2.1 Controller is assembled on card (104x68)mm and designed for installation into the turnstile housing or power supply box.

19 LEDs are mounted on controller card. Their purpose is as follows:

- 5 LEDs initiate state of inputs for peripheral connections «INP1» ÷ «INP5»;
- LED «POWER» initiates availability of power voltage 5V;
- LED «OPERATE» initiates operability of microprocessor;
- 7 LEDs initiate state of outputs for peripheral connections «OUT1» ÷ «OUT7»;
- LEDs «SENSOR» initiate state of rotor position sensor;
- LEDs «RX» and «TX» initiate respectively reception and transmittance in serial port.

40 connecting terminals are mounted on card, 14 of which are designed for peripheral connections. The rest of them are standby or designed for connection to the turnstile's units.

The controller's appearance is shown in the Figure 3.

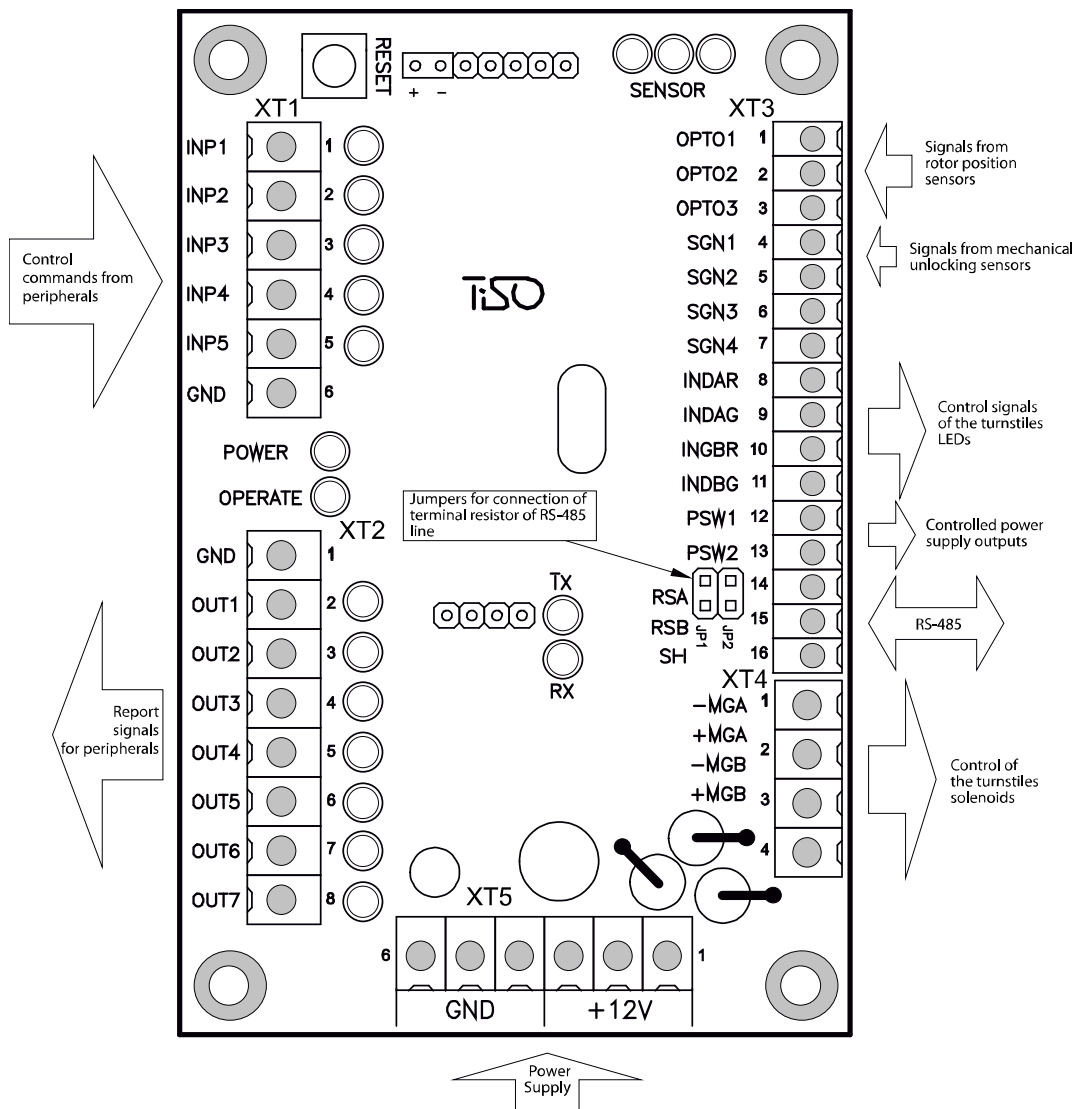

Figure 3 – Appearance of the controller PCB.112.21.20.00

### 1.8.2.2 Technical features

Controller technical features are specified in the Table 7.

Table 7

Parameter description	Parameter value
Number of inputs for reception of control commands	5
Number of inputs for connection of rotation sensors	7
Type of inputs	logical
Type of outputs	open collector
Voltage of logical «1»	(3÷5)V
Voltage of logical «0»	(0÷2,2)V
Maximum peak voltage supplied to the inputs «INP1» ÷ «INP5»	15V
Peak voltage switched by transistors of signal outputs	50V
Peak current switched through signal outputs	0,1A
Power supply voltage of controller	(9÷15)V
Peak consumption current	0,15A
Number of signal reception and transmission serial ports (RS-485)	1
Climatic version and category of location according to the GOST 15150-69	NF4

### 1.8.2.3 Description of operation

The controller PCB.112.21.20.00 operates according to the program fed into the microprocessor memory. The turnstile's mechanism motor controller and LED displays<sup>1</sup> are controlled according to control commands and status of rotor position sensors based on the logic entered into the program. Control commands can be transmitted via RS-485 (from control panel) or logical inputs (by closing and opening of inputs «INP1» ÷ «INP5» on «GND»).

Controller (along with the turnstile) can be in the «INITIAL STATE» (closed for access) or in the following access modes:

- «SINGLE ACCESS IN ONE DIRECTION»;
- «FREE ACCESS IN ONE DIRECTION»;
- «LOCKING OF ACCESS».

Other operating modes are combinations of various or similar modes in different directions:

- Single access in one direction and any mode in opposite direction.
- Free access in one direction and any mode in opposite direction.
- Locking of access in one direction and any mode in opposite direction.

#### 1.8.2.3.1 «INITIAL STATE»

Controller is in this mode, if there are no commands «OPEN A/B» and the turnstile's rotor is set to the point 0°.

In this mode rotor is locked by electromagnetic brake: denied red LED is lit in both directions<sup>1</sup>.

#### «SINGLE ACCESS IN ONE DIRECTION»

In this mode controller unlocks rotor through solenoid in one direction with possibility of revolving to 120°. It enables the turnstile access of one pedestrian.

Controller is switched to «SINGLE ACCESS IN ONE DIRECTION», if in the «INITIAL STATE» it receives «OPEN A/B» command (i.e. active level of signal is sent to the input «INP4» or «INP5»). In this case the turnstile is open within action period of signal. The command can also be sent through RS-485. Then start of rotor rotation is expected prior to the end of delay of «WAITING FOR START OF ACCESS».

Sequence of controller operations after reception of «OPEN A/B» command is as follows:

- Delay of «WAITING FOR START OF ACCESS» is initiated (factory setting 5 sec.).
- Controller PCB.201.01.00.00 deenergizes solenoid and rotor is unlocked in the relevant direction.
- LEDs are switched from red to green according to authorized access<sup>1</sup>.

Then two alternatives of events are possible:

1) first alternative: If within active status of «OPEN A/B» («INP4»/«INP5») or during delay of «WAITING FOR START OF ACCESS» rotation of rotor is not started, then controller PCB.201.01.00.00 is reset to «INITIAL STATE»;

2) second alternative: if in the above mentioned cases rotation of rotor is started, then current is delivered to motor winding via outputs «MOT1» and «OT2» (X2/9 and X2/10) and barrier rods rotate in the relevant direction. Current, rotation speed and barrier rod position are controlled during rotation:

- When rotor rotates to 6°, the output signal «ACCESS A/B IS OCCUPIED» («OUT5») becomes active. Output signal «START OF ACCESS A/B» («OUT1» or «OUT2») becomes active.

LED display is switched from green to red indicating that access is occupied<sup>1</sup>.

• When rotor rotates to 54° the output signal «START OF ACCESS A/B» («OUT1» or «OUT2») is removed. Delay of «WAITING FOR START OF ACCESS» is reset.

- When rotor rotates to 64°, the signal «DETECTION OF ACCESS A/B» («OUT3» or «OUT4») appears.
- After turnstile access by pedestrian blades continue to rotate smoothly forward (turn additionally), gradually slowing down, and when the turning angle 120° is reached, barrier rods are kept in this position by means of servomotor and electromagnetic brake.

- When rotor rotates to 120°, the signals «ACCESS A/B IS OCCUPIED» («OUT5») and «DETECTION OF ACCESS A/B» («OUT3» or «OUT4») are cleared and then availability of «OPEN A/B» (INP4» or «INP5») command, conforming to the applicable direction, is checked. If by this moment the command remains active by this moment, controller goes to «FREE ACCESS» mode.

#### 1.8.2.3.2 «FREE ACCESS IN ONE DIRECTION»

In this mode rotor can easily rotate in direction of free access.

In the «FREE ACCESS» mode green LED of the relevant direction is blinking<sup>1</sup>.

Controller is switched to this mode in two cases:

- first: when the «OPEN A/B» (input «INP4» or «INP5») command is kept in active status at the moment of crossing by rotor the point 120° at the termination of «SINGLE ACCESS»;
- second: after reception of the «FREE ACCESS» command in the relevant direction through RS-485.

After controller is switched to «FREE ACCESS» mode, output signals of «OCCUPIED ACCESS», «ACCESS DETECTION» of the relevant direction are generated as described in the section 1.8.2.3.1. Exit of this mode in «INITIAL STATE» is taken place after cancellation of the «OPEN A/B» command or reception of the «FREE ACCESS CANCELATION» command through RS-485. But it will take place not instantly and only when rotor reaches one the starting points 0°, 120° or 240°, i.e. if the free access cancellation arises during the started access it will be completed as free.

#### 1.8.2.3.3 «AUTHORIZATION OF SINGLE ACCESS IN TWO DIRECTIONS»

Since the turnstile having one rotor cannot be rotated in two directions simultaneously, controller can only issue command to the motor controller PCB.201.01.00.00 to unlock rotor in two directions and after access in one of directions is stated, rotation of rotor in opposite direction will be locked by electromagnetic brake.

Controller is switched to this mode if in the «INITIAL STATUS» it simultaneously acquires «OPEN A» and «OPEN B» commands. The second signal can also come during the time when the first signal is already active but rotation of rotor did not start yet.

At the same time:

- 1) Controller will send the relevant command to the motor controller PCB.201.01.00.00 to unlock rotor in both directions.
- 2) It will switch LEDs in both directions from red to green<sup>1</sup>.
- 3) It will initiate two delays of «WAITING FOR START OF ACCESS A and B» for each access separately, which are counted from the moment of acquisition of commands.
- 4) After rotor is revolved to 6° in any side, the opposite direction will be locked and LED is switched to red<sup>1</sup>.

Then controller operates as described in the chapter «SINGLE ACCESS IN ONE DIRECTION».

If during active state of the «OPEN A» and «OPEN B» signals or during «WAITING FOR START OF ACCESS» rotor was not revolved in any side to the angle more than 6°, then controller PCB.112.21.20.00 is switched to «INITIAL STATE» and switches the motor controller PCB.201.01.00.0 to «INITIAL STATE» by the relevant command.

#### 1.8.2.3.4 «LOCKING OF ACCESS»

Locking function can be activated only by control panel.

After activation of «LOCKING OF ACCESS A or B» the turnstile's rotor is locked in the appropriate direction and authorized access commands will be ignored in locked direction.

Locked direction is indicated by blinking red color<sup>1</sup>.

Controller's contacts designed for connection of peripherals are shown in the Table 8.

Table 8

Connector / Contact No	Designation	Direction	Description	Signal parameters and description
XT1/1	INP1	ENTRY	Not applicable	1) logical «0» (0÷2,2)V; 2) logical «1»
XT1/2	INP2	ENTRY		
XT1/3	INP3	ENTRY		

XT1/4	INP4 («TO BE OPENED A»)	ENTRY	Command «OPEN FOR SINGLE/FREE ACCESS»; free access appears when entry is kept in active states after the angle 120° is reached rotor	(3÷5)V; 3) active level of signal (factory setting) – logical «0»; 4) voltage on open input < 5V
XT1/5	INP5 («TO BE OPENED B»)	ENTRY		
XT1/6	GND (common)			
XT2/1	GND (common)			
XT2/2	OUT1 («START OF ACCESS A»)	EXIT	Signal is generated by controller when rotor is rotated from 6° to 54° in the appropriate direction	1) type of output – open collector; 2) peak voltage on privacy key 55V; 3) peak current of public key 100mA; 4) resistance of public key (5÷7)Ohm; 5) active level of signal (factory setting) – logical «0»
XT2/3	OUT2 («START OF ACCESS B»)	EXIT		
XT2/4	OUT3 («DETECTION OF ACCESS A»)	EXIT	Signal is generated by controller when rotor is rotated from 64° to 120° in the appropriate direction	
XT2/5	OUT4 («DETECTION OF ACCESS B»)	EXIT		
XT2/6	OUT5 («ACCESS IS OCCUPIED»)	EXIT	Signal is generated by controller when rotor is rotated from 6° to 120° in any direction	
XT2/7	OUT6 («ERROR»)	EXIT	Signal is generated by controller when fault of behaviour is detected	
XT2/8	OUT7	EXIT	Not applicable	
XT3/1	OPTO1	ENTRY	Used for obtaining of information about turnstile rotor position	
XT3/2	OPTO2	ENTRY		
XT3/3	OPTO3	ENTRY		
XT3/4	SGN1	ENTRY	Not applicable	
XT3/5	SGN2	ENTRY		
XT3/6	SGN3	ENTRY		
XT3/7	SGN4	ENTRY		
XT3/8	INDAR	EXIT	Used for control of turnstile LED displays <sup>1</sup>	
XT3/9	INDAG	EXIT		
XT3/10	INDBR	EXIT		
XT3/11	INDBG	EXIT		
XT3/12	PSW1 («PANIC»)	EXIT	Not applicable	1) type of output – open emitter; 2) voltage on output in ON state 12V;
XT3/13	PSW2 («SENSOR»)	EXIT	Not applicable	

				3) peak current consumed from the output 1A; 4) resistance of public key 0,25Ohm
XT3/14	RSA		Used for data transmission via serial port	Interface RS-485
XT3/15	RSB			Interface RS-485
XT3/16	SH			RS-485 SCREEN
XT4/1	- MGA	EXIT	Not applicable	1) type of output – open collector; 2) peak voltage on privacy key 50V; 3) peak current of public key 9A; 4) resistance of public key 0,11Ohm
XT4/3	- MGB	EXIT		
XT4/2	+ MGA		Not applicable	
XT4/4	+ MGB			
XT5/1	GND (common)			
XT5/2	GND (common)			
XT5/3	GND (common)			
XT5/4	+ 12V			1) power supply voltage 12V; 2) consumption current < 150mA
XT5/5	+ 12V			
XT5/6	+ 12V			

## 2 INTENDED USE

### 2.1 Operation limitations

2.1.1 The turnstile must be used in the environment specified in the p. 1.1.4 of this document subject to the specifications listed in the section 1.2.

#### 2.1.2 IT IS PROHIBITED:

- 1) **UNINTENDED USE OF THE TURNSTIL** (see the section 1 «DESCRIPTION AND OPERATION»);
- 2) **TO USE THE TURNSTILE UNEARTHED;**
- 3) **TO USE HEATING PIPES AND RADIATIONS AS WELL AS PIPES OF CENTRAL WATER SUPPLY FOR EARTHING;**
- 4) **TO REPAIR AND ADJUST WITHOUT DEENERGIZING;**
- 5) **TO RELOCATE THE OBJECTS EXCEEDING THE PASSAGEWAY WIDTH THROUGH THE TURNSTILE ACCESS AREA;**
- 6) **TO JERK AND IMPACT ON BLADES OR OTHER PARTS THE PRODUCT, WHICH MAY CAUSE THEIR MECHANICAL DEFORMATION OR DAMAGE.**

2.1.3 It is not allowed to use the turnstile:

- at the presence of mechanical rattle in movable parts of the turnstile;
- when metalwork of the turnstile and its components and accessories are mechanically damaged.

#### 2.1.4 List of special conditions of operation

- Mean time of the turnstile access (in single access mode) equals to 3 sec.
- The force applied by accessor to barrier rod should not exceed 60H.
- For augmentation of the turnstile's traffic flow capacity in case of emergency escape door or gate can be installed near the turnstile.



# ATTENTION: MANUFACTURER WARNS OF NECESSITY TO KEEP SEALS OF THE MANUFACTURER ON THE TURNSTILE’S COMPONENT PARTS!

## 2.2 Layout and installation

2.2.1 The turnstile and components of delivery kit are delivered to the installation site in the factory packing. The turnstile should be unpacked only on installation site.

2.2.2 Preparation of the turnstile for installation (dismounting) and commissioning should be performed according to this OM with mandatory observation of the safety measures specified in p. 2.1 and general electrical safety code.

2.2.3 The turnstile is installed in the following order:

- inspect the turnstile for integrity, absence of visual damages and defects;
- verify the turnstile’s completeness;
- prepare installation site for mounting of ready-to-install turnstile: surface should be plain, hard and without defects (corrugations, overlaps etc.);
- protective ducts or conduits should be laid to the center of the turnstile’s rotor and to installation sites of power supply units and to control sites to pull power and control cables of the turnstile;
- mark the hole drilling places and check the marking according to the Appendix A. For this purpose it is necessary to install the turnstile rotor and enclosures and make sure that the holes on flanges match the floor or foundation holes. Modify the marking, if required.

The turnstile should be installed and fixed only after all the turnstile electric connection cables are pulled. For access to fixation holes (see the Figure 1) it is necessary to remove sheeting, fix the turnstile by means of Redibolt (anchor with jacket and screw) and make sure that the installed turnstile is stable;

- earthen the turnstile, connect power cable to the turnstile and control panel according to the wiring diagram (see the Appendix C).

After the required installation sheeting should be placed back.

## 2.3 Preparation for use

### 2.3.1 Commissioning instructions

Prior to energizing of the turnstile:

- 1) make sure of proper connection and good condition of all connecting cables;
- 2) clear the area of the turnstile’s blades rotation from foreign particles.
- 3) check revolving of rotor: rotor with blades should revolve smoothly and after revolving to 120° it should be locked.

When mains cable of power supply unit is connected to the network the flag rotation is locked. The turnstile is set in initial state. Flag with blades is locked from rotation in both directions and access between enclosures is barred by one of the blades.

The turnstile is set in initial state: entry and exit LED displays are red (« >< » is lit)<sup>1</sup>.

### 2.3.2 Required inspections

2.3.2.1 When rotor turnstile is commissioned as part of Access Control System or when it is controlled by means of control panel (complete with reader racks and LED display panel) it is necessary to perform inspections specified in the Table 9. During inspections the wiring diagram according to the Appendix C and the control panel according to the Appendix B should be used.

Table 9

Operating Mode	Mode Setting	LED Display <sup>1</sup>	Functional Check
1 Turnstile is closed in both directions (initial state)	–	Red LED display is lit	Make sure that rotor can’t be rotated in any direction
2 Single access in one direction	Push the «SINGLE» access button to access in chosen	Green arrow of single access is lit in chosen direction and red LED display is lit in	Make sure that in case of gentle push in the direction of authorized access rotor starts rotating and stops after rotation

	direction («A» or «B»)	opposite direction	to 120°. Rotor should not start rotation independently
3 Single access in both directions	Push both «SINGLE» access buttons to access in two directions («A» or «B»)	Green arrows of single access are lit in both directions	Make sure that in case of gentle push in the direction of authorized access rotor starts rotating and stops after rotation to 120°. Rotor should not start rotation independently. Repeat the check for opposite direction
4 Free access in one direction	Push the «FREE» access button to access in the selected direction («A» or «B»)	Green arrow of free access in chosen direction is blinking and red LED display is lit in opposite direction	Make sure that at each push in the direction of free access rotor rotates to 120° and stops. Rotor should not start rotation independently
5 Free access in both directions	Push both «FREE» access buttons to access in two directions («A» or «B»)	Green arrow of authorized free access is blinking in chosen direction and green arrow is blinking	Make sure that at each push in any direction rotor rotates to 120° and stops. Rotor should not start rotation independently
6 Single access in one direction and free access in opposite direction	Push the «SINGLE» access button to access in the selected direction («A» or «B») and «FREE» access button to pass in opposite direction	Green arrow of authorized single access is lit in chosen direction and green arrow of authorized free access is blinking in opposite direction	Make sure that rotor can be rotated to 120° in the direction of single access only once and in the direction of free access rotor can be rotated many times. Rotor should not start rotation independently
7 Single access in one direction and locked access in opposite direction	Push the «SINGLE» access button to access in the selected direction («A» or «B») and the «LOCK» button to lock access in opposite direction	Green arrow of authorized single access is lit in chosen direction and red LED display is blinking in the locked access direction	Make sure that rotor can be rotated to 120° in the direction of single access only once and in the direction of locked access rotor can't be switched neither in «SINGLE» mode nor in «FREE» mode
8 Free access in one direction and locked access in opposite direction	Push the «FREE» access button to access in selected direction («A» or «B») and the «LOCKING» button to lock access in opposite direction	Green arrow of authorized free access is blinking in chosen direction and red LED display is blinking in the locked access direction	Make sure that rotor can be rotated to 120° in the direction of free access many times and in the direction of locked access rotor can't be switched neither in «SINGLE» mode nor in «FREE» mode
9 Locked access in one direction	Push the «LOCKING» button to lock access in selected	Red LED display of locked access in one chosen direction is blinking	Make sure that rotor can't be switched to the direction of locked access neither in «SINGLE» mode nor in

	direction («A» or «B»)*		«FREE» mode
10 Locked access in both directions	Push both «LOCKING» button to lock access in two directions («A» or «B»)**	Red LED display of locked access in both directions is blinking	Make sure that rotor can't be switched neither to «SINGLE» mode nor to «FREE» mode in any direction
* In this case other control panel buttons of single and free access in chosen direction are locked			
** In this case all control panel buttons of single and free access in both directions are locked			

2.3.2.3 The turnstile is ready for long-term operation.

## 2.4 Contingency actions

For emergency evacuation of people (in case of fire, acts of God etc.) and providing of free access the turnstile must be unlocked from control panel by sending the relevant command.

## 3 MAINTENANCE

### 3.1 General instructions

3.1.1 Commissioning and subsequent maintenance of the turnstile should be performed only by the staff to be in charge of the turnstile.

3.1.2 The turnstile can be serviced only by the staff having the relevant electrical safety qualification level according to the national requirements.

3.1.3 The turnstile can be installed and operated only by the qualified safety instructed staff having the relevant class of permit to work with electrical facilities with voltage up to 1000V, awaring of this OM, design and the turnstile's principle of operation.

### 3.2 Safety Measures

3.2.1 During maintenance of the turnstile the relevant safety measures, specified in p. 2.1, must be observed.

**IT IS FORBIDDEN TO USE DEFECTIVE APPLIANCES, TOOLS, FUSES, INSTRUMENTATION SERVICE LIFE OF WHICH EXPIRED. MEASURING DEVICES, WHICH TERM OF CHECKING HAS ENDED**

3.2.2 When instrumentations are prepared for operation it is necessary to comply with the safety requirements specified in instrumentation instruction manuals.

### 3.3 Maintenance procedure

3.3.1 Maintenance of the turnstile includes preventive measures which are taken according to established frequency to maintain the turnstile in operational condition, decreasing of component wearing and prevention of faults and malfunctions.

3.3.2 Daily and periodic maintenance of the turnstile are recommended.

Normally the daily maintenance is carried out before the beginning of work or during operational timeout and includes visual inspection of the turnstile's housing, and, if required, mechanical troubleshooting, elimination of corrosion and pollution from the surface.

**IT IS FORBIDDEN TO USE DEFECTIVE APPLIANCES, TOOLS, FUSES, INSTRUMENTATION SERVICE LIFE OF WHICH EXPIRED. MEASURING DEVICES, WHICH TERM OF CHECKING HAS ENDED**

3.3.3 Periodic maintenance is performed at least twice a year and includes as follows:

- visual inspection of the turnstile's housing, control mechanism and other components for absence of corrosion, warps and other mechanical defects and pollutions;
- visual inspection of power and connection cables' condition as well as earthing;
- verification of the turnstile's performance during manual control in the modes specified in the Table 9 or as part of access control system using cards and badges;
- checking of reliability of tightness of the turnstile's screw joints.

## 4 ROUTINE MAINTENANCE

### 4.1 General instructions

Possible malfunctions of the turnstile are listed in the Table 10 and are remedied by customer. More complicated malfunctions are remedied by manufacturer's representative.

**ATTENTION: INSPECTION, CLEANING, REPAIR OF THE TURNSTILE'S COMPONENTS MUST BE PERFORMED ONLY AFTER DEENERGIZING OF THE TURNSTILE!**

### 4.2 List of possible malfunctions

List of possible malfunctions of the turnstile and their remedies are specified in the Table 10.

Table 10

Symptom	Possible cause	Remedy
1 Blades are not brought to zero position	Lack of voltage on servomotor	12V voltage to be checked in the circuit of gear motor. If the voltage is lower than 12V refer to the point 2 of this table
	Electric circuit is broken	Malfunction to be discovered and remedied
	Adjustment of servomotor is faulted	Servomotor to be adjusted
2 Lack of 12V voltage	Power supply unit is out of order	Power supply to be replaced
	Electric circuit is broken	Malfunction to be discovered and remedied

### 4.3 Postrepair checkout

After performance of repair operating capacity of the turnstile is checked by means of control panel according to the Table 9.

## 5 TRANSPORTATION AND STORAGE

5.1 It is forbidden to subject the turnstile to jerks and impacts during storage. For lifting and handling of the turnstile it is necessary to use transportation trolleys. In storage facility there should not be aggressive gases and vapours causing corrosion. Storage ambient temperature should not be lower +5°C and higher +40°C and relative humidity should not be more than 80% at the temperature 20°C.

5.2 The ready-to-install turnstile is transported in railway or special containers, closed vehicle, waterborne (in ship's hold) according to the transportation regulations related to the relevant mode of transport.

Transportation on open platforms is allowed. In this case the packed turnstile should be covered with canvas. Ambient temperature during transportation should not be lower -40°C and higher +50°C.

After transportation or storage of the turnstile at negative temperatures or increased humidity the turnstile should be kept indoor with normal climatic conditions without original packing within 12 hours before commissioning:

- 1) ambient temperature: + 15°C to +35°C;
- 2) relative humidity: 45% to 80 %;
- 3) atmospheric pressure: 84,0 to 106,7kPa (630-800 mm Hg).

## 6 UTILIZATION

The turnstile does not contain hazardous materials and special measures are not required for utilization.

## 7 MANUFACTURER'S WARRANTY AND CONDITIONS OF WARRANTY MEAINTEENANCE

7.1. The manufacturer guarantees good state and declared quality of the turnstile if conditions of transportation, storage, installation and operation are observed by the consumer.

7.2 The warranty period of the turnstile from the date of sale is 12 months, unless otherwise specified by mutual agreement.

Manufacturer:  
**«TiSO-PRODUCTION» Company**  
72 Yamskaya str., 03680, Kiev, Ukraine  
Tel.: +38 (044) 461-79-69  
Tel./Fax: +38 (044) 586-46-47  
E-mail: [export@tiso.ua](mailto:export@tiso.ua), [log1@tiso.ua](mailto:log1@tiso.ua)  
[www.tiso-turnstiles.com](http://www.tiso-turnstiles.com)

Our equipment complies with requirements of the European Standards:

EN ISO 12100:2010; EN 614-1:2006+A1:2009; EN 1037:1995+A1:2008; EN 60204-1:2006; EN 953:1997+A1:2009; ISO 3864:1995; EN ISO 13857:2008; EN ISO 13849-1:2006; EN 1088:1995; EN ISO 13732-1:2008

and is in conformity with requirements of the following EC Directives:

2004/108/EC; 2006/95/ EC; 2006/42/ EC



Appendix A  
Design, overall and installation dimensions  
of the rotor turnstile

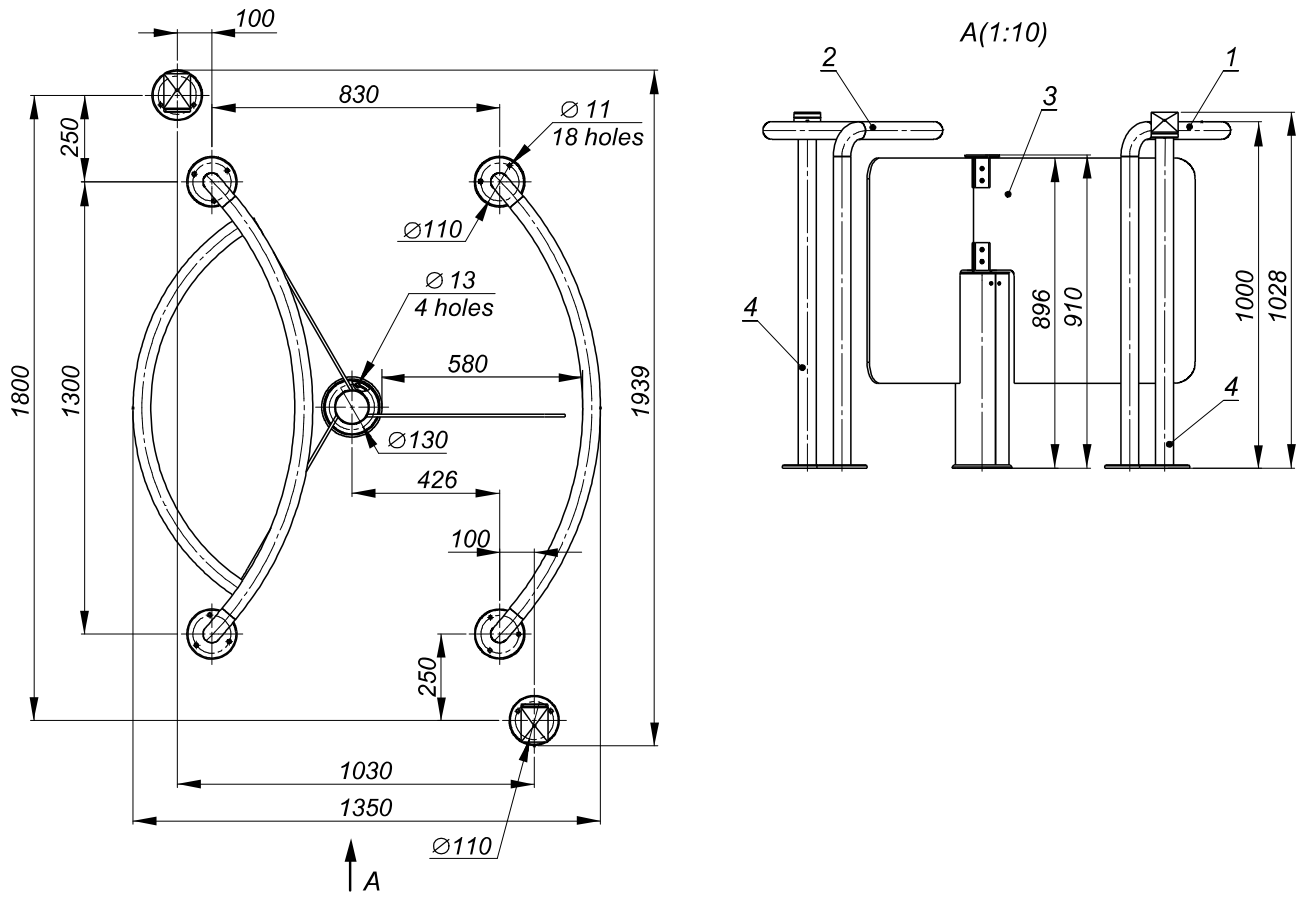

- |                        |                               |
|------------------------|-------------------------------|
| 1 – central enclosure; | 3 – servo-operated turnstile; |
| 2 – side enclosure;    | 4 – reader racks              |

Figure A.1 – Installation of the rotor turnstile

Appendix B  
Control panel and connection diagram

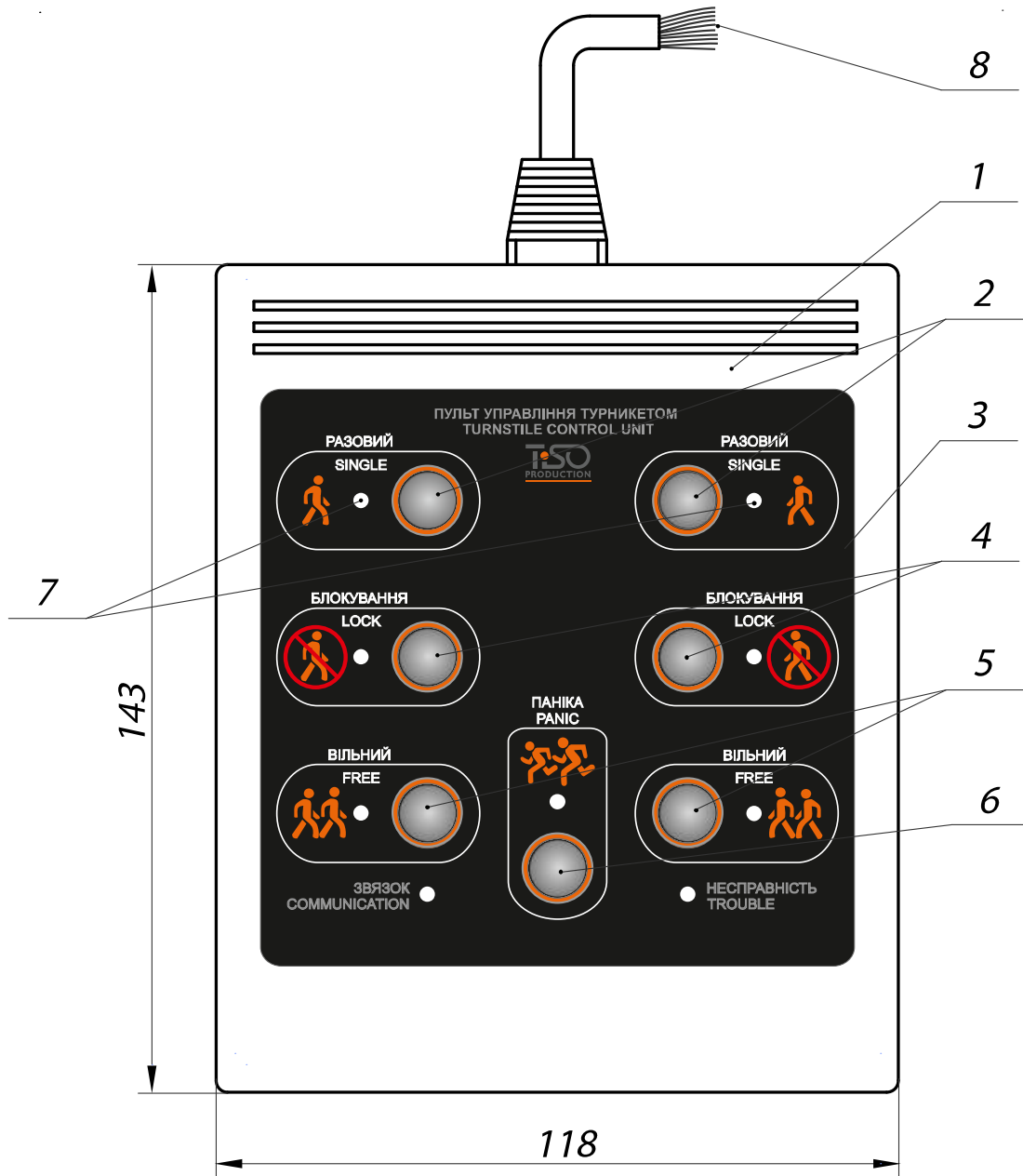

- |   |                                       |
|---|---------------------------------------|
| 1 – housing;                            | 5 – «FREE ACCESS» mode control button |
| 2 – «SINGLE ACCESS» mode control button | 6 – «PANIC» mode control button;      |
| 3 – front plate;                        | 7 – access direction LED display;     |
| 4 – «LOCKING» mode control button;      | 8 – controller connection terminals   |

Figure B.1 – Control panel AUJA.114.02.00.00 for turnstiles

Appendix B (continued)  
Control panel and connection diagram

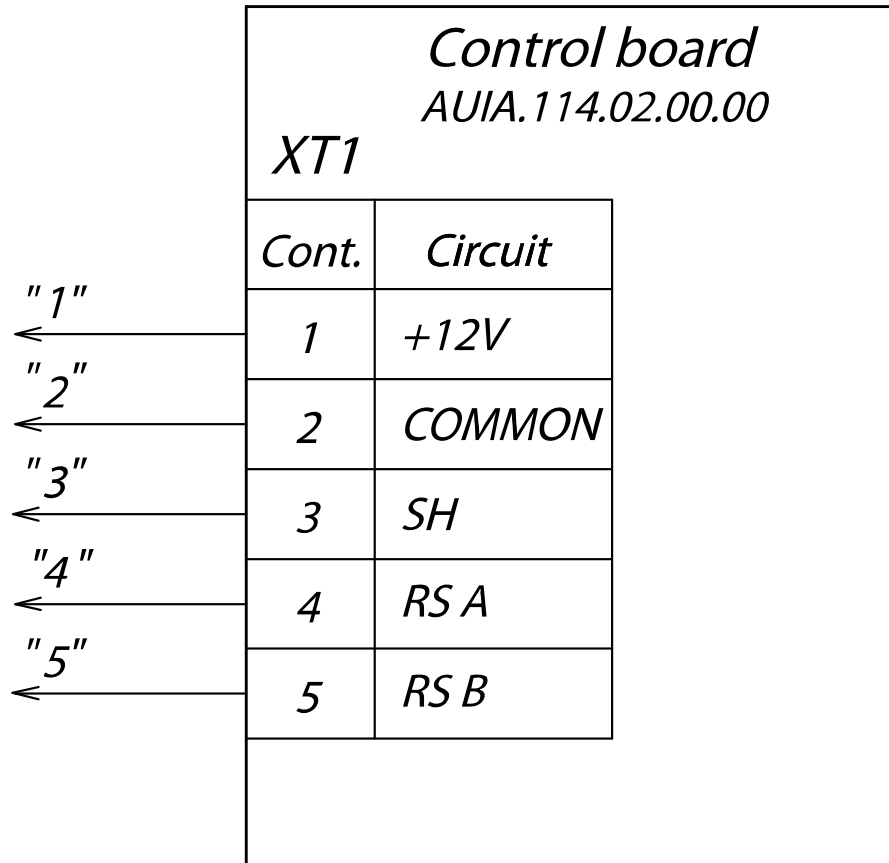

Figure B.2 – Connection diagram of the control panel  
AUIA.114.02.00.00



## Appendix C Wiring diagram of the turnstile

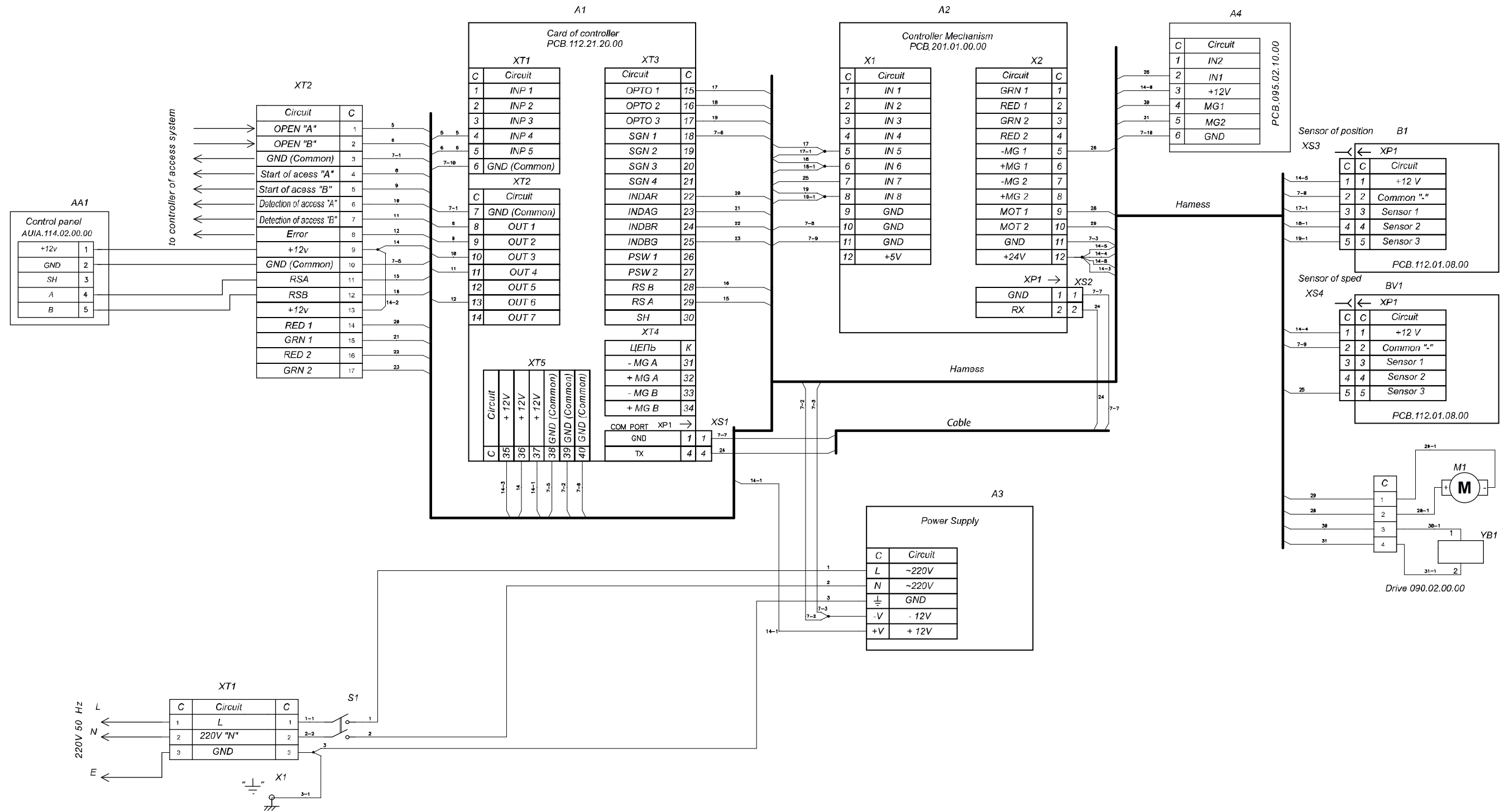

Figure C.1 – Wiring diagram of the rotor turnstile T3.POC.XC